

---

## CYLINDER HEAD/VALVES

---

SCHEMATIC DRAWING (XCITING 500/500 AFI) -----	9- 1
SCHEMATIC DRAWING (XCITING 250/300 AFI) -----	9- 2
SERVICE INFORMATION-----	9- 3
TROUBLESHOOTING-----	9- 5
CYLINDER COMPRESSION TEST -----	9- 6
CYLINDER HEAD COVER (XCITING 500/500 AFI)-----	9- 7
CYLINDER HEAD COVER (XCITING 250/300 AFI)-----	9- 8
CAMSHAFT (XCITING 500/500 AFI) -----	9- 9
CAMSHAFT (XCITING 250/300 AFI) -----	9-14
ROCKER ARMS (XCITING 500/500 AFI) -----	9-17
ROCKER ARMS (XCITING 250/300 AFI) -----	9-18
CYLINDER HEAD-----	9-19



# 9. CYLINDER HEAD/VALVES XCITING 500/500 AFI/250/300 AFI

---

## SCHEMATIC DRAWING (XCITING 500/500 AFI)

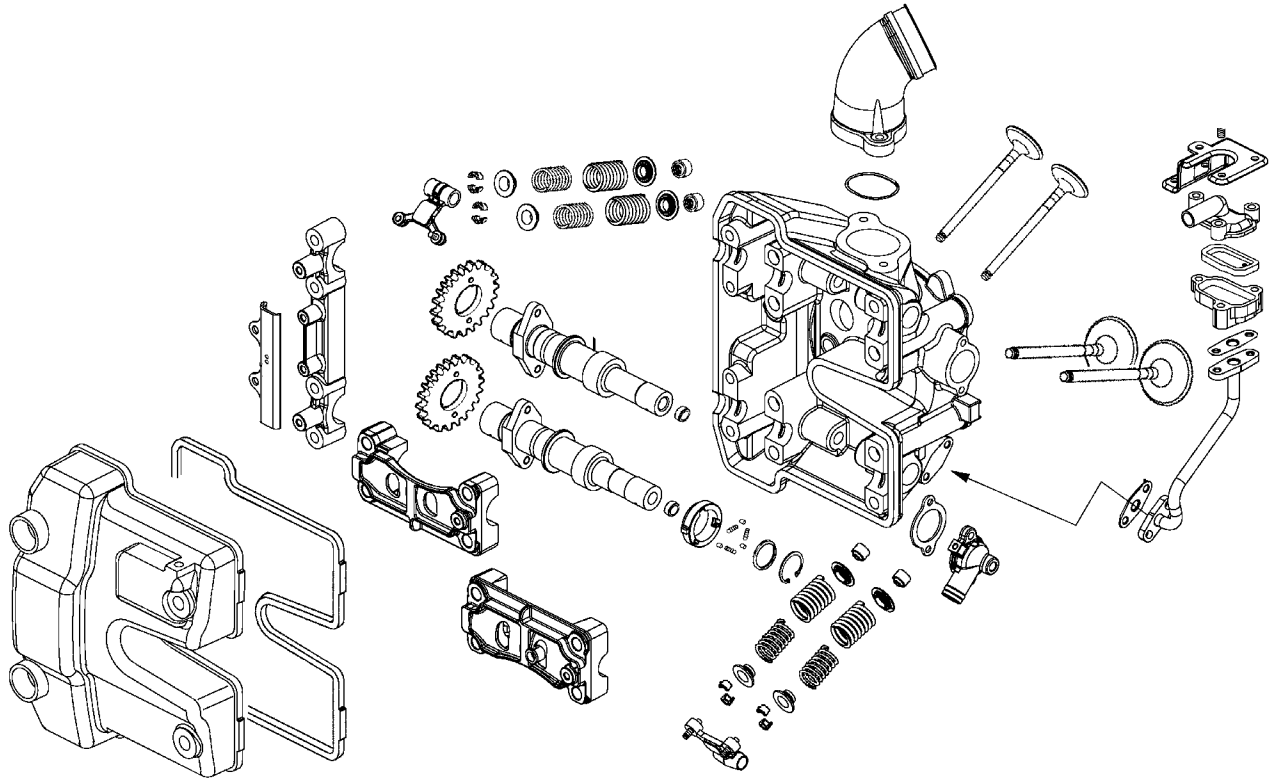

# 9. CYLINDER HEAD/VALVES

XCITING 500/500 AFI/250/300AFI

## SCHEMATIC DRAWING (XCITING 250/XCITING 300 AFI)

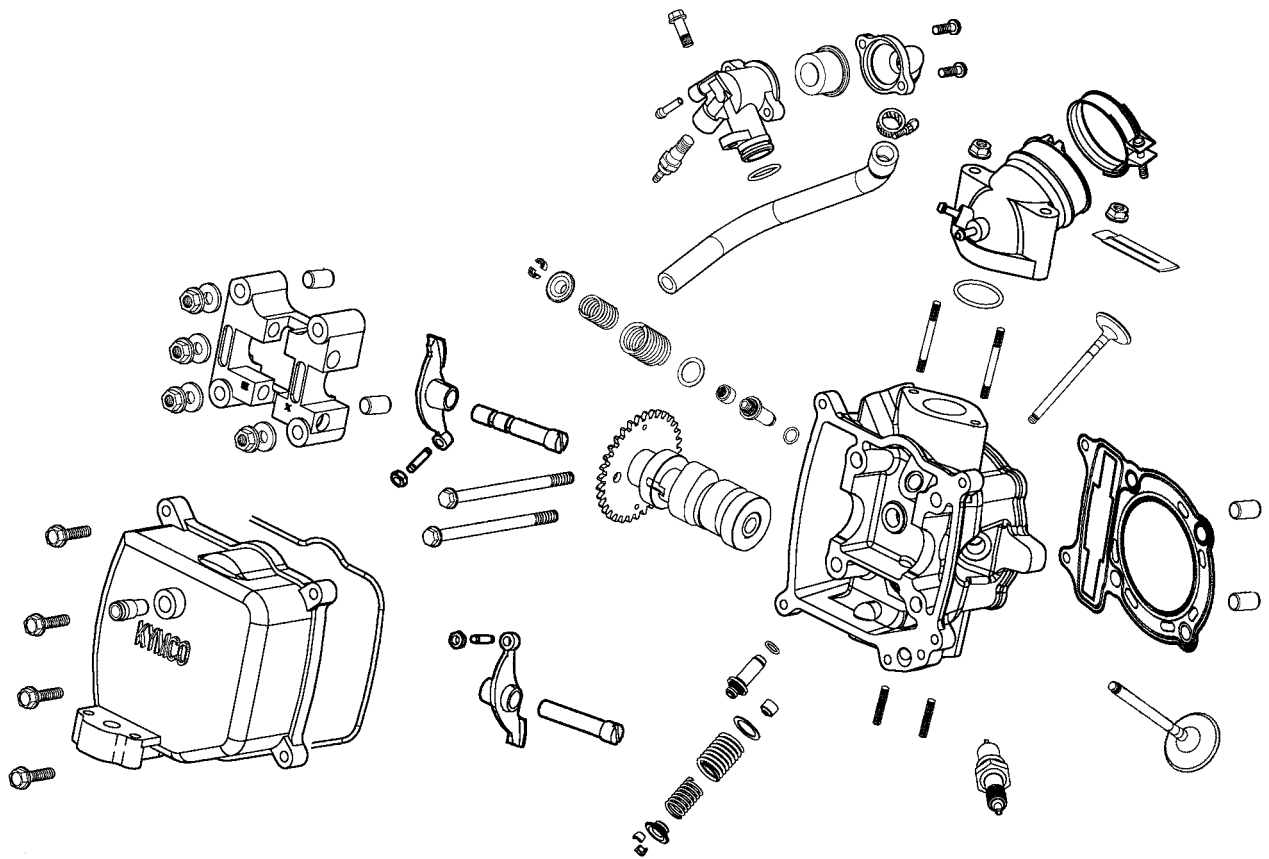

## 9. CYLINDER HEAD/VALVES XCITING 500/500 AFI/250/300 AFI

### SERVICE INFORMATION

#### GENERAL INSTRUCTIONS

- The cylinder head can be serviced with the engine installed in the frame. Coolant in the radiator and water jacket must be drained first.
- When assembling, apply molybdenum disulfide grease or engine oil to the valve guide movable parts and valve arm sliding surfaces for initial lubrication.
- The valve rocker arms are lubricated by engine oil through the cylinder head engine oil passages. Clean and unclog the oil passages before assembling the cylinder head.
- After disassembly, clean the removed parts and dry them with compressed air before inspection.
- After removal, mark and arrange the removed parts in order. When assembling, install them in the reverse order of removal.

#### SPECIFICATIONS (XCITING 500/500 AFI)

Unit: mm (in)

Item		Standard	Service Limit
Valve clearance (cold)	IN	0.1 mm (0.004 in)	—
	EX	0.1 mm (0.004 in)	—
Cylinder head compression pressure		13 kg/cm <sup>2</sup> (185 psi, 1300 kPa)	—
Cylinder head warpage		—	0.05 (0.002)
Camshaft cam height	IN	37.2614 (1.4905)	37.11 (1.4844)
	EX	37.0084 (1.4803)	36.86 (1.4744)
Valve rocker arm I.D.	IN	10 (0.4)~10.015 (0.4006)	10.1 (0.404)
	EX	10 (0.4)~10.015 (0.4006)	10.1 (0.404)
Valve rocker arm shaft O.D.	IN	9.975 (0.399)~9.99 (0.3996)	9.9 (0.396)
	EX	9.975 (0.399)~9.99 (0.3996)	9.9 (0.396)
Valve stem O.D.	IN	4.975 (0.199)~4.99 (0.1996)	4.925 (0.197)
	EX	4.955 (0.1982)~4.97 (0.1988)	4.915 (0.1966)
Valve guide I.D.	IN	5 (0.2)~5.015 (0.2006)	5.03 (0.2012)
	EX	5 (0.2)~5.015 (0.2006)	5.03 (0.2012)
Valve stem-to-guide clearance	IN	0.01 (0.004)~0.037 (0.0015)	0.08 (0.0032)
	EX	0.03 (0.0012)~0.057 (0.0023)	0.1 (0.004)

## 9. CYLINDER HEAD/VALVES

XCITING 500/500 AFI/250/300AFI

### SPECIFICATIONS (XCITING 250/XCITING 300 AFI)

Unit: mm (in)

Item		Standard	Service Limit
Valve clearance (cold)	IN	0.1 mm (0.004 in)	—
	EX	0.1 mm (0.004 in)	—
Cylinder head compression pressure		15 kg/cm <sup>2</sup> (213 psi, 1500 kPa)	—
Cylinder head warpage		—	0.05 (0.002)
Camshaft cam height	IN	34.2987 (1.371948)	34.14 (1.3656)
	EX	34.1721 (1.366884)	34.02 (1.3608)
Valve rocker arm I.D.	IN	10 (0.4)~10.015 (0.4006)	10.1 (0.404)
	EX	10 (0.4)~10.015 (0.4006)	10.1 (0.404)
Valve rocker arm shaft O.D.	IN	9.972 (0.399)~9.987 (0.3995)	9.9 (0.396)
	EX	9.972 (0.399)~9.987 (0.3995)	9.9 (0.396)
Valve stem O.D.	IN	4.975 (0.199)~4.99 (0.1996)	4.925 (0.197)
	EX	4.955 (0.1982)~4.97 (0.1988)	4.915 (0.1966)
Valve guide I.D.	IN	5 (0.2)~5.012 (0.2005)	5.03 (0.2012)
	EX	5 (0.2)~5.012 (0.2005)	5.03 (0.2012)
Valve stem-to-guide clearance	IN	0.01 (0.004)~0.037 (0.0015)	0.08 (0.0032)
	EX	0.03 (0.0012)~0.057 (0.0023)	0.1 (0.004)

### TORQUE VALUES (XCITING 500/500 AFI)

Cylinder head bolt (13)	13 N•m (1.3 kgf•m, 9 lbf•ft)	Apply engine oil to threads
Cylinder head bolt (1 – 4)	48 N•m (4.8 kgf•m, 35 lbf•ft)	Apply engine oil to threads
Cylinder head bolt (5 – 12)	23 N•m (2.3 kgf•m, 17 lbf•ft)	Apply engine oil to threads
Cylinder head cover bolt	10 N•m (1 kgf•m, 7 lbf•ft)	
Cylinder head cover bolt	10 N•m (1 kgf•m, 7 lbf•ft)	
Breather separator bolt	13 N•m (1.3 kgf•m, 9 lbf•ft)	
Cam chain tensioner bolt	12 N•m (1.2 kgf•m, 9 lbf•ft)	
Tensioner pivot bolt	10 N•m (1 kgf•m, 7 lbf•ft)	
Rocker arm shaft	45 N•m (4.5 kgf•m, 32 lbf•ft)	

### TORQUE VALUES (XCITING 250/XCITING 250 AFI)

Cylinder head cap nut	25 N•m (2.5 kgf•m, 18 lbf•ft)	Apply engine oil to threads
Valve clearance adjusting nut	9 N•m (0.9 kgf•m, 6.5 lbf•ft)	Apply engine oil to threads
Cylinder head cover bolt	12 N•m (1.2 kgf•m, 8.6 lbf•ft)	

### SPECIAL TOOLS

Valve spring compressor	A120E00040
-------------------------	------------

**TROUBLESHOOTING**

- The poor cylinder head operation can be diagnosed by a compression test or by tracing engine top-end noises.

**Poor performance at idle speed**

- Compression too low

**Compression too low**

- Incorrect valve clearance adjustment
- Burned or bent valves
- Incorrect valve timing
- Broken valve spring
- Poor valve and seat contact
- Leaking cylinder head gasket
- Warped or cracked cylinder head
- Poorly installed spark plug

**Compression too high**

- Excessive carbon build-up in combustion chamber

**White smoke from exhaust muffler**

- Worn valve stem or valve guide
- Damaged valve stem oil seal

**Abnormal noise**

- Incorrect valve clearance adjustment
- Sticking valve or broken valve spring
- Damaged or worn camshaft
- Worn cam chain tensioner
- Worn camshaft and rocker arm

## 9. CYLINDER HEAD/VALVES

XCITING 500/500 AFI/250/300AFI

### CYLINDER COMPRESSION TEST

Warm up the engine to normal operating temperature.  
Stop the engine and remove the spark plug cap and remove the spark plug (page 3-10).



Spark Plug Cap

Install a compression gauge into the spark plug hole.

Open the throttle all the way and crank the engine with the starter motor until the gauge reading stops rising.

The maximum reading is usually reached 4 – 7 seconds.

\* To avoid discharging the battery, do not operate the starter motor for more than seven seconds.

Compression Gauge



#### Compression pressure:

**XCITING 500/500 AFI:**

**13 kg/cm<sup>2</sup> (185 psi, 1300 kPa)**

**XCITING 250/300 AFI:**

**15 kg/cm<sup>2</sup> (213 psi, 1500 kPa)**

Low compression can be caused by:

- ♦ Blown cylinder head gasket
- ♦ Improper valve adjustment
- ♦ Valve leakage
- ♦ Worn piston ring or cylinder

High compression can be caused by:

- ♦ Carbon deposits in combustion chamber or on piston head

## 9. CYLINDER HEAD/VALVES XCITING 500/500 AFI/250/300 AFI

### CYLINDER HEAD COVER (XCITING 500/500 AFI)

#### DISASSEMBLY

Remove the floorboard (page 2-6).  
Remove the spark plug caps (page 9-6)  
Disconnect the crankcase breather hose from the cylinder head cover (page 8-3).

Remove the four bolts and cylinder head cover.

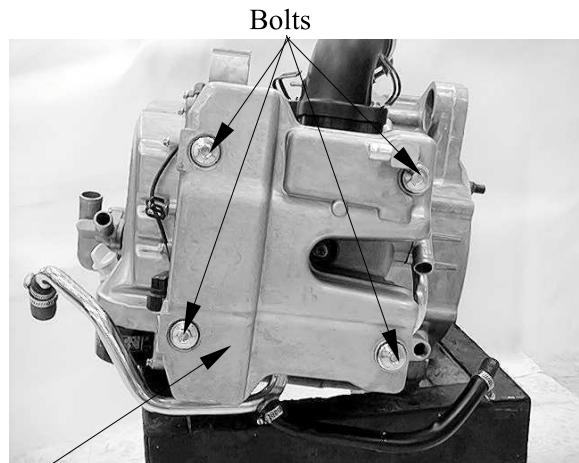

Cylinder Head Cover

Remove the cylinder head cover packing.



Remove the bolts and breather separator.

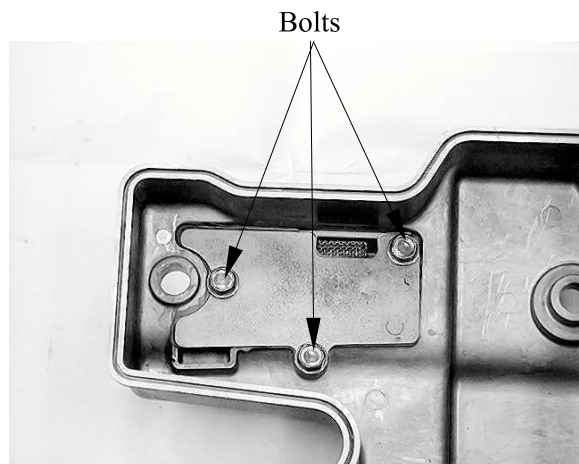



## 9. CYLINDER HEAD/VALVES

Remove the gasket.

### ASSEMBLY

Assembly is in the reverse order of disassembly.

### Torque:

**Breather separator bolt:**

**13 N•m (1.3 kgf•m, 9 lbf•ft)**

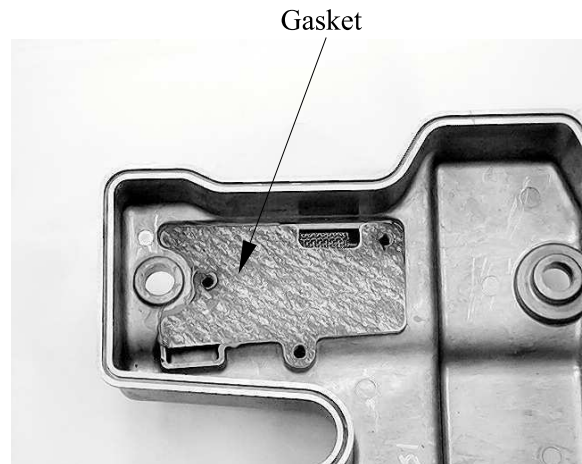

### CYLINDER HEAD COVER (XCITING 250/300 AFI)

#### DISASSEMBLY

Remove the floorboard (page 2-6).  
Disconnect the crankcase breather hose from the cylinder head cover (page 8-11).

Remove the four bolts and two nuts, then remove cylinder head cover.

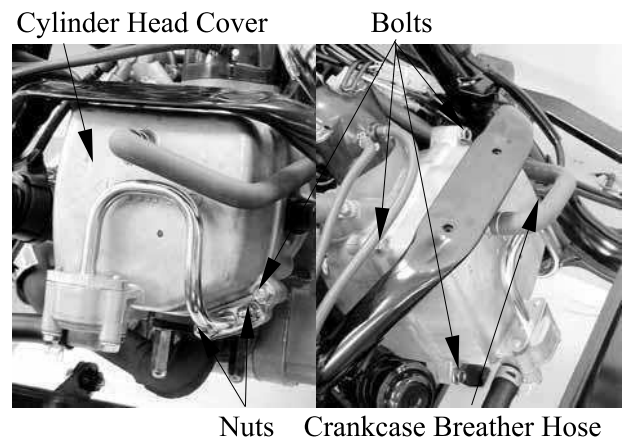

Remove the cylinder head cover O-ring.

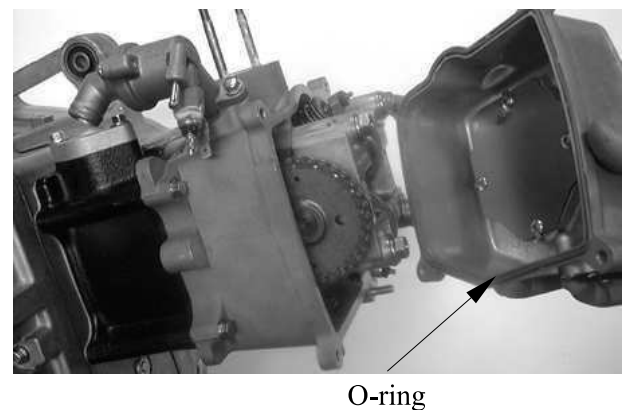

## 9. CYLINDER HEAD/VALVES

XCITING 500/500 AFI/250/300 AFI

### CAMSHAFT (XCITING 500/500 AFI)

#### REMOVAL

Remove the cylinder head cover (page 9-6).  
Turn the crankshaft clockwise and align the "T" mark on the flywheel with the index mark on the right crankcase cover (page 3-12).

Remove the cam chain tensioner lifter sealing bolt, spring and sealing washer.

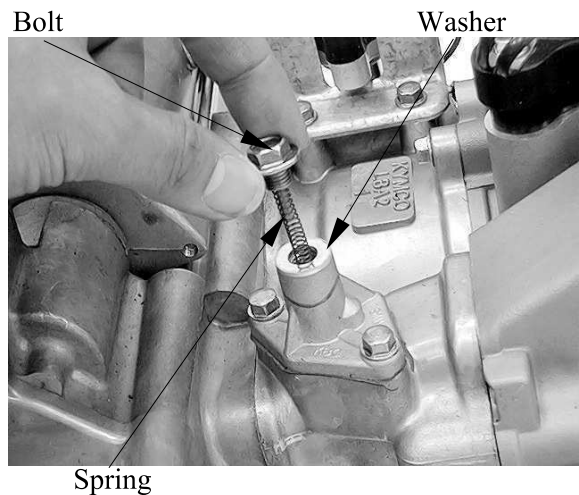

Remove the two bolts, cam chain tensioner and gasket.

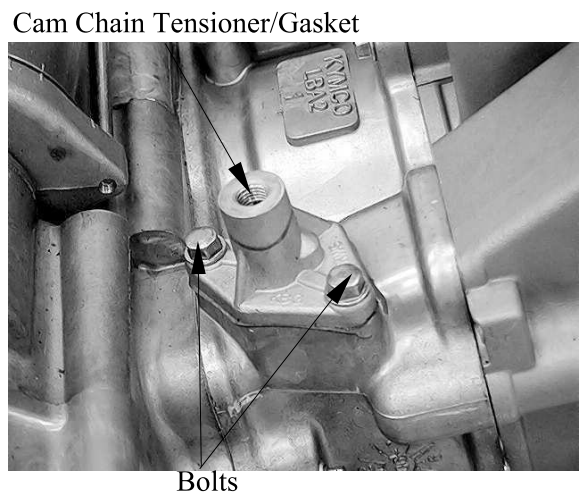

Remove the two bolts and cam chain guide.

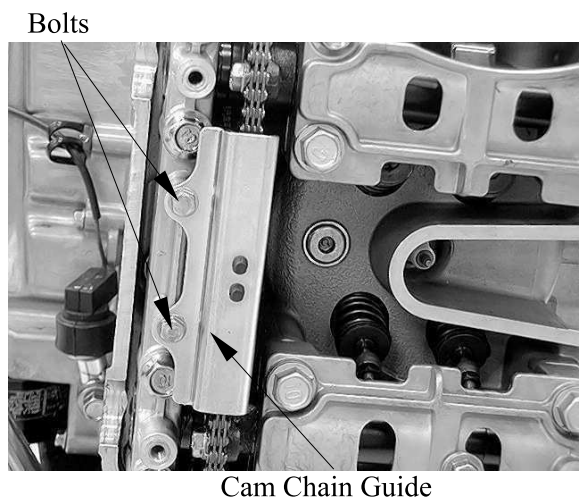

## 9. CYLINDER HEAD/VALVES

Loosen and remove the twelve camshaft holder bolts in a crisscross pattern in several steps, then remove the camshaft holders.

\* Suspend the cam chain with a piece of wire to prevent the chain from falling into the crankcase.

Camshaft Holders                      Bolts

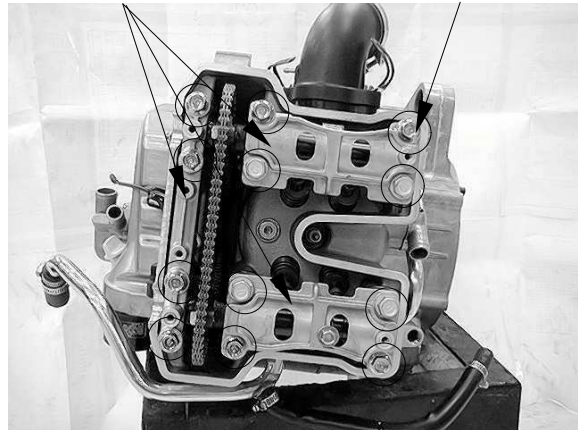

Remove the camshafts.

Camshafts

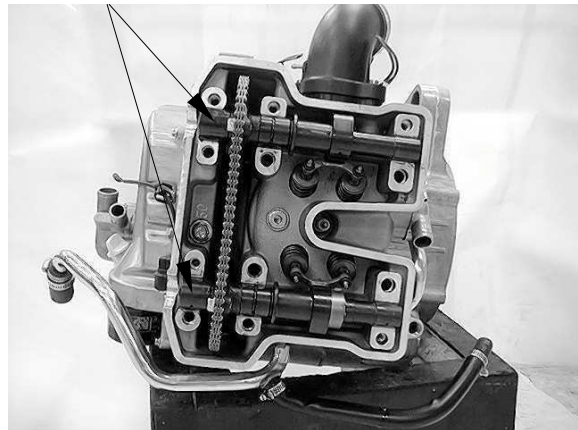

Refer to the page 9-28 to install the camshafts.

## 9. CYLINDER HEAD/VALVES XCITING 500/500 AFI/250/300 AFI

### INSPECTION

#### Cam chain guide

Inspect the cam chain slipper surface of the cam chain guide for wear or damage.



#### Camshaft holder

\* Always replace the camshaft holder and cylinder head in pairs

Inspect the bearing surface of each camshaft holder for scoring, scratches, or evidence of insufficient lubrication.

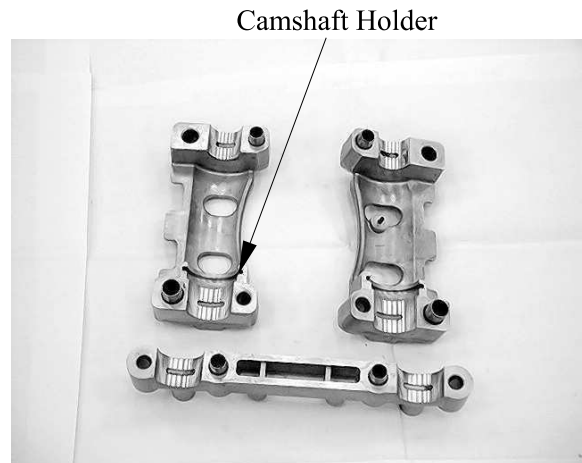

Check the stop pin spring on the exhaust camshaft holder for damage.

Replace the stop pin assembly with a new one if the spring is damaged.

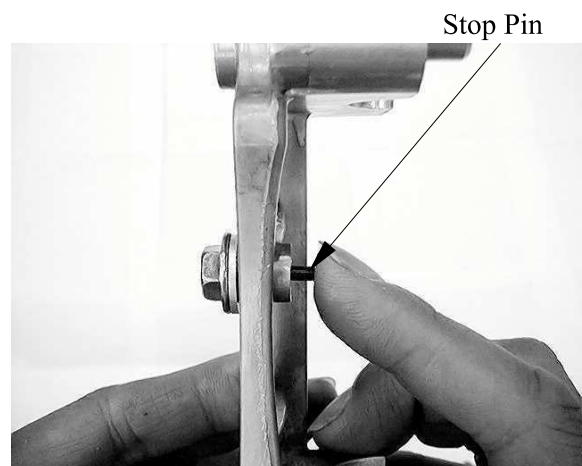

## 9. CYLINDER HEAD/VALVES

### Camshaft

Support both ends of the camshaft with V-blocks and check the camshaft runout with a dial gauge.

**Service limit: 0.05 mm (0.002 in)**

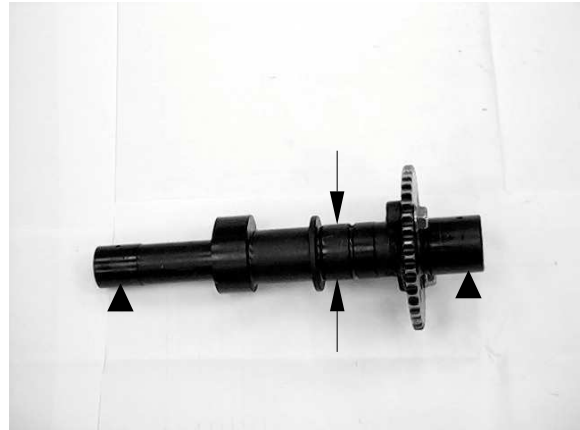

Inspect camshaft lobes for pitting/scratches/blue discoloration.

Measure the cam lobe height.

**Service Limits: IN : 37.11 mm (1.4844 in)**

**EX: 36.86 mm (1.4744 in)**

If any defects are found, replace the camshaft with a new one, then inspect lubrication system.

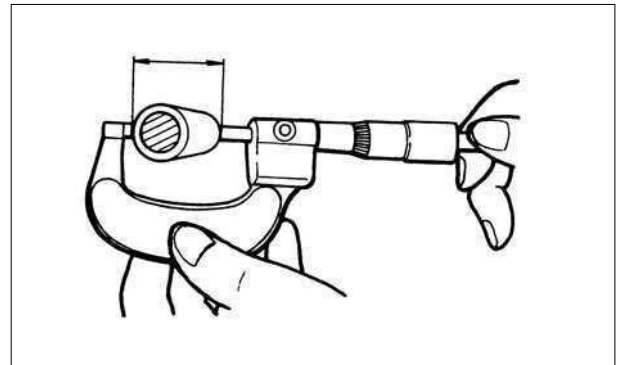

Check the decompression system by turning the decompressor cam on the exhaust camshaft.

You should be able to turn the decompressor cam clockwise smoothly, but the decompressor should not turn counterclockwise.



**Cam chain tensioner**

Check the one-way cam operation (tensioner)

Unsmooth operation → Replace.



## 9. CYLINDER HEAD/VALVES

### CAMSHAFT (XCITING 250/300 AFI)

#### REMOVAL

Turn the A.C. generator flywheel so that the "T" mark on the flywheel aligns with the index mark on the right crankcase cover (page 3-13).

Hold the round hole on the camshaft gear facing up and the location is the top dead center on the compression stroke.

Remove the cam chain tensioner lifter sealing bolt.

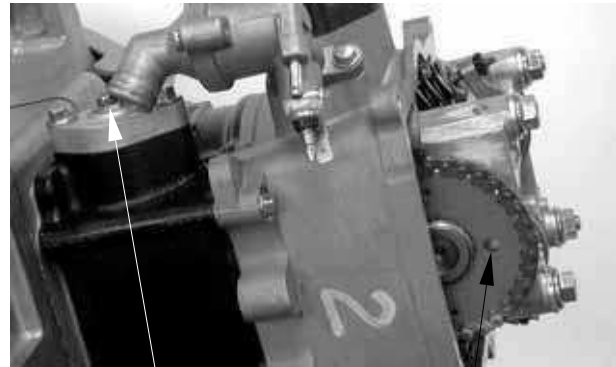

Cam Chain Tensioner

Round Hole

Turn the cam chain tensioner screw clockwise to pull the tensioner rod all the way in.

Tensioner Screw

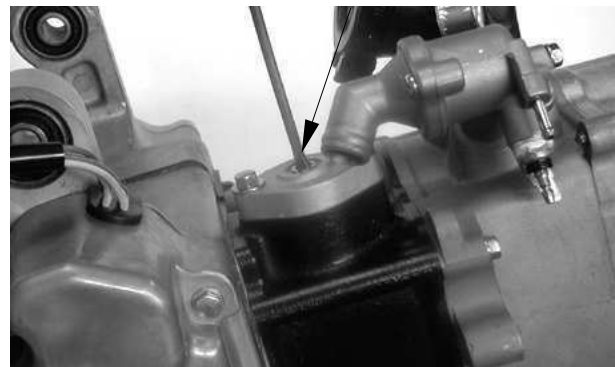

Remove the four cap nuts attaching the camshaft holder.

- \* • Diagonally loosen the cylinder head cap nuts in 2 or 3 times.

Camshaft Holder

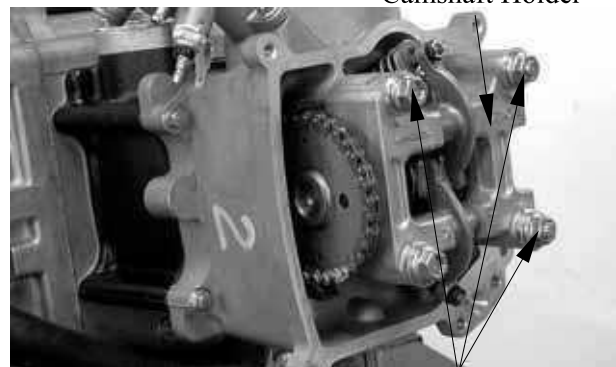

Cap Nuts



## 9. CYLINDER HEAD/VALVES XCITING 500/500 AFI/250/300 AFI

---

Remove the camshaft holder and dowel pins.

Camshaft Holder/Dowel Pins



Remove the camshaft gear from the cam chain to remove the camshaft.

Cam Chain

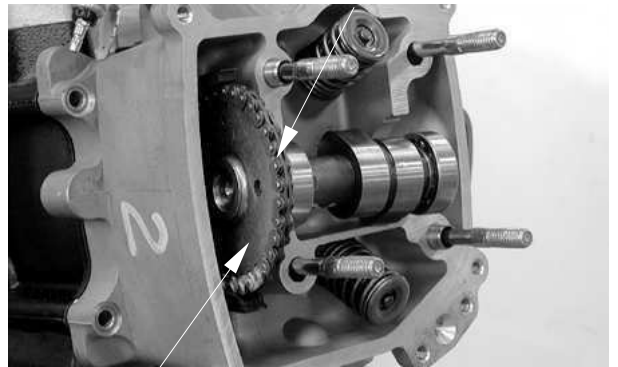

Camshaft Gear



#### INSPECTION

##### Camshaft

Check each cam lobe for wear or damage.  
Measure the cam lobe height.

**Service Limits:** IN : 34.14 mm (1.3656 in)  
EX: 34.02 mm (1.3608 in)

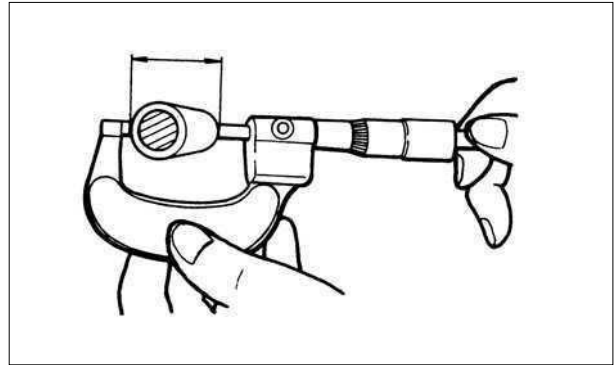

Check each camshaft bearing for play or damage. Replace the camshaft assembly with a new one if the bearings are noisy or have excessive play.



## 9. CYLINDER HEAD/VALVES XCITING 500/500 AFI/250/300 AFI

### ROCKER ARMS (XCITING 500/500 AFI)

#### REMOVAL

Remove the camshaft (page 9-9).

Remove the rocker arm shafts and washers, then remove the rocker arms.

Refer to page 9-27 to install the rocker arms.

Rocker Arms

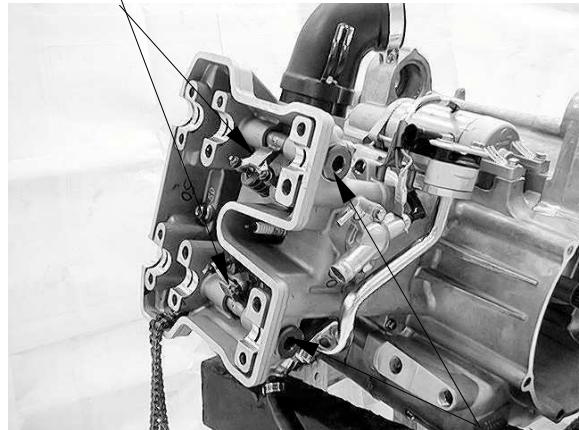

Rocker Arm Shafts/Washers

#### INSPECTION

##### Rocker arm shaft

Inspect the rocker arm shaft for blue discoloration or grooves.

If any defects are found, replace the rocker arm shaft with a new one, then inspect lubrication system.

Measure each rocker arm shaft O.D.

Measure the I.D. of each rocker arm.

Measure arm to shaft clearance.

Replace as a set if out of specification.

**Service limits: 0.1 mm (0.004 in)**

Rocker Arm Shaft



Inspect the rocker arm bore, cam lobe contact surface and adjuster surface for wear/pitting/scratches/blue discoloration.

If any defects are found, replace the rocker arm shaft with a new one, then inspect lubrication system.

Measure each rocker arm shaft O.D.

Measure the I.D. of each rocker arm.

Measure arm to shaft clearance.

Replace as a set if out of specification.

**Service limits: 0.1 mm (0.004 in)**

Rock Arm

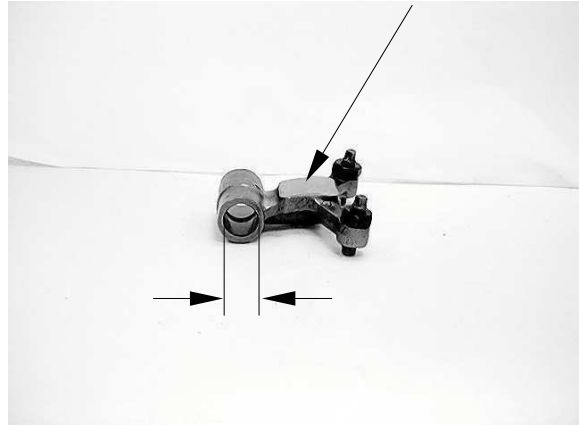

## 9. CYLINDER HEAD/VALVES

XCITING 500/500 AFI/250/300AFI

### ROCKER ARMS (XCITING 250/300 AFI)

#### REMOVAL

Remove the camshaft (page 9-14).

Remove the rocker arm shafts and then remove the rocker arms.

#### INSPECTION

##### Camshaft holder

Inspect the bearing surface of camshaft holder for scoring, scratches, or evidence of insufficient lubrication.

##### Rocker arm shaft

Inspect the rocker arm shaft for blue discoloration or grooves.

If any defects are found, replace the rocker arm shaft with a new one, then inspect lubrication system.

Measure each rocker arm shaft O.D.  
 Measure the I.D. of each rocker arm.  
 Measure arm to shaft clearance.  
 Replace as a set if out of specification.

**Service limits: 0.1 mm (0.004 in)**

Inspect the rocker arm bore, cam lobe contact surface and adjuster surface for wear/pitting/scratches/blue discoloration.

If any defects are found, replace the rocker arm shaft with a new one, then inspect lubrication system.

Measure each rocker arm shaft O.D.  
 Measure the I.D. of each rocker arm.  
 Measure arm to shaft clearance.  
 Replace as a set if out of specification.

**Service limits: 0.1 mm (0.004 in)**

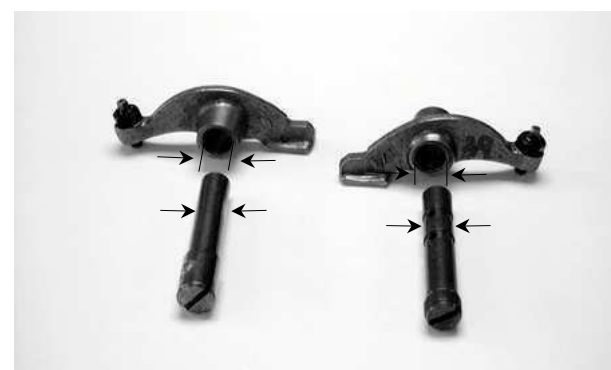
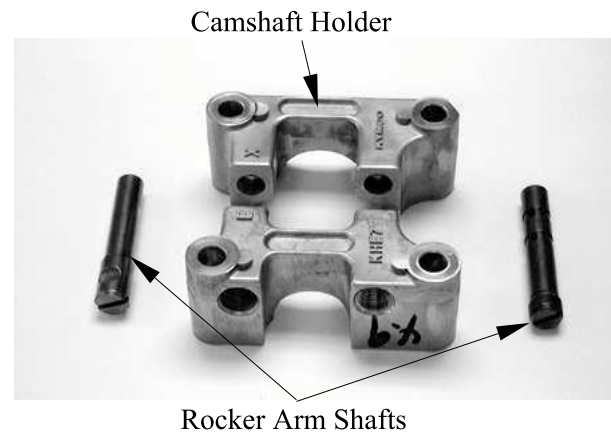
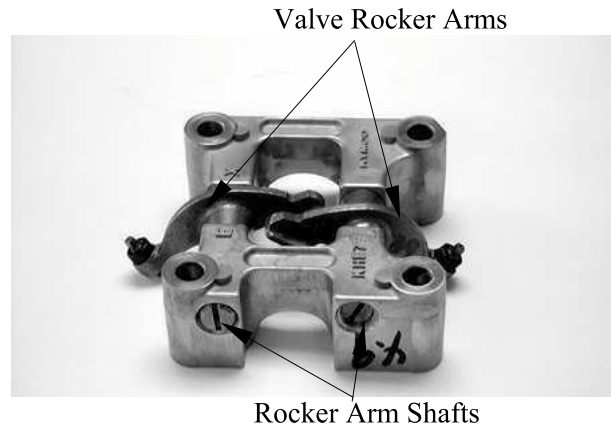

# 9. CYLINDER HEAD/VALVES XCITING 500/500 AFI/250/300 AFI

## CYLINDER HEAD

### REMOVAL (XCITING 500/500 AFI)

\* Always replace the camshaft holder and cylinder head in pairs

Remove the rock arms (page 9-17).

Remove the two bolts, intake pipe and insulator.

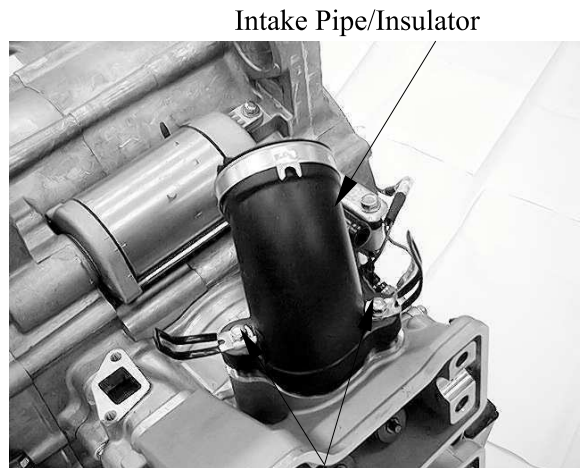

Bolts

Remove the two bolts, two nuts, pair reed valve and gasket.

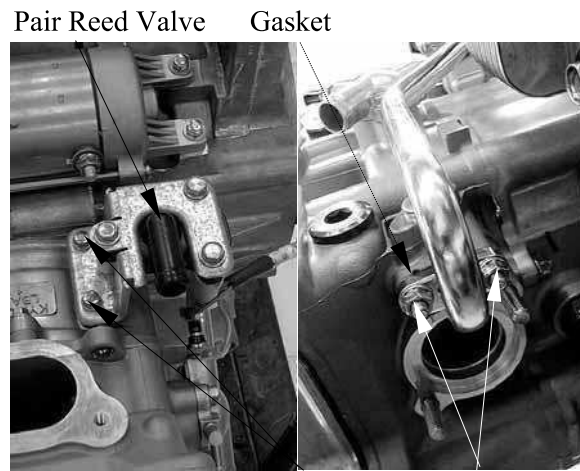

Nuts

Remove the two bolts, water joint, gasket and water stop collar.

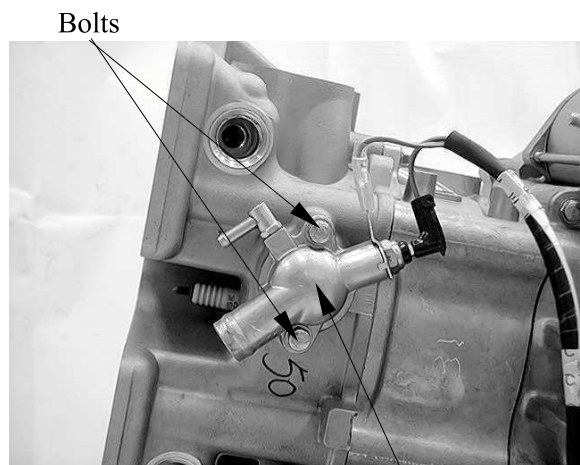

Water Joint/Gasket/Water Stop Collar

## **9. CYLINDER HEAD/VALVES**

Remove the three bolts and cylinder head.

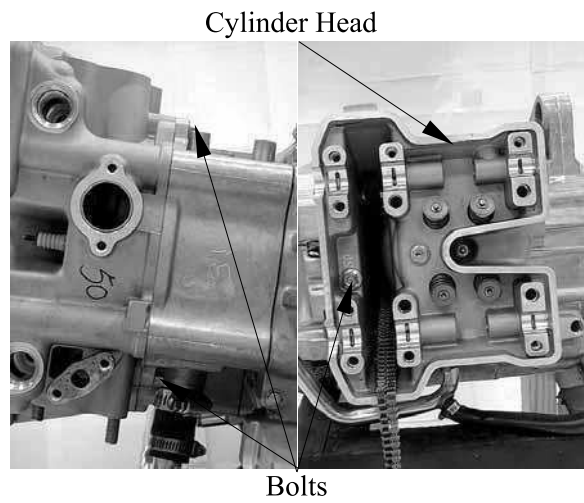

Remove the dowel pins and cylinder head gasket.

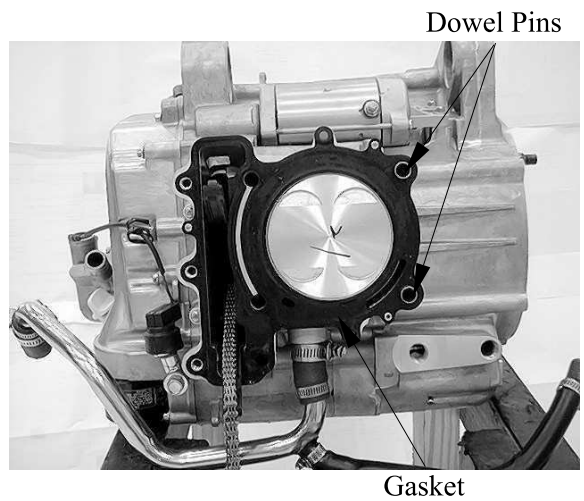

## 9. CYLINDER HEAD/VALVES XCITING 500/500 AFI/250/300 AFI

### REMOVAL (XCITING 250/300 AFI)

First drain the coolant from the radiator and water jacket, then remove the thermostat water hose.

Remove the camshaft. (page 9-14).

Remove the carburetor and intake pipe.

Remove the two cylinder bolts.

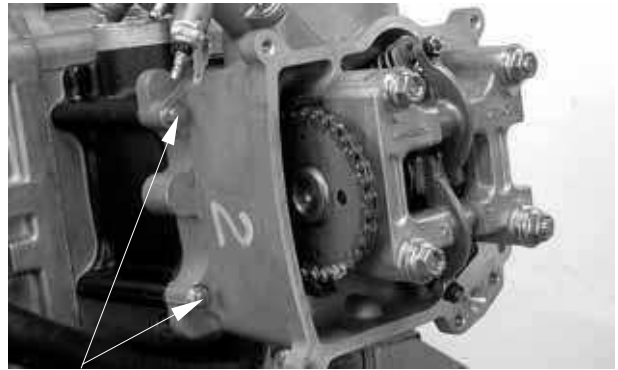

Cylinder Bolts

Remove the bolt attaching the thermostat housing and the thermostat housing.  
Remove the cylinder head.

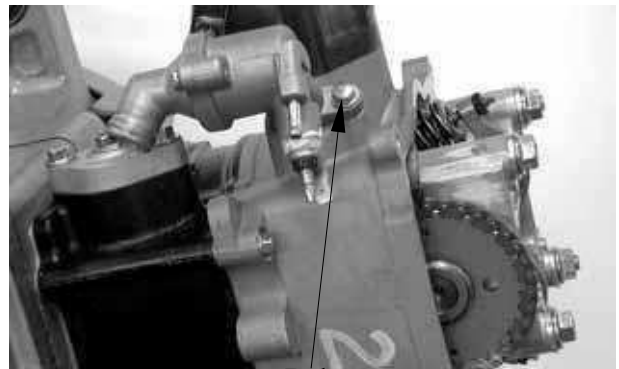

Bolt

Remove the dowel pins and cylinder head gasket.  
Remove the cam chain guide.  
Remove all gasket material from the cylinder head mating surface.

\* Be careful not to drop any gasket material into the engine.

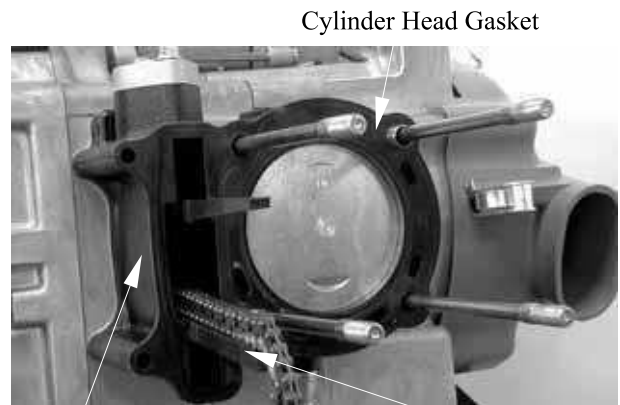

Cylinder

Cam Chain Tensioner Slipper

## CYLINDER HEAD DISASSEMBLY

Remove the valve spring cotters, retainers, springs, spring seats, oil seals and valves using a valve spring compressor.

\*

- Be sure to compress the valve springs with a valve spring compressor.
- Mark all disassembled parts to ensure correct reassembly.

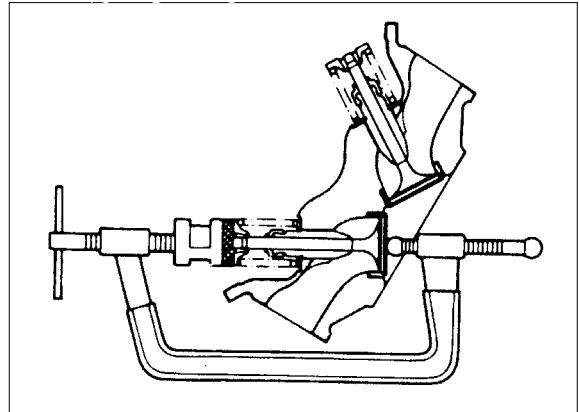

**Special tool:**

**Valve Spring Compressor    A120E00040**

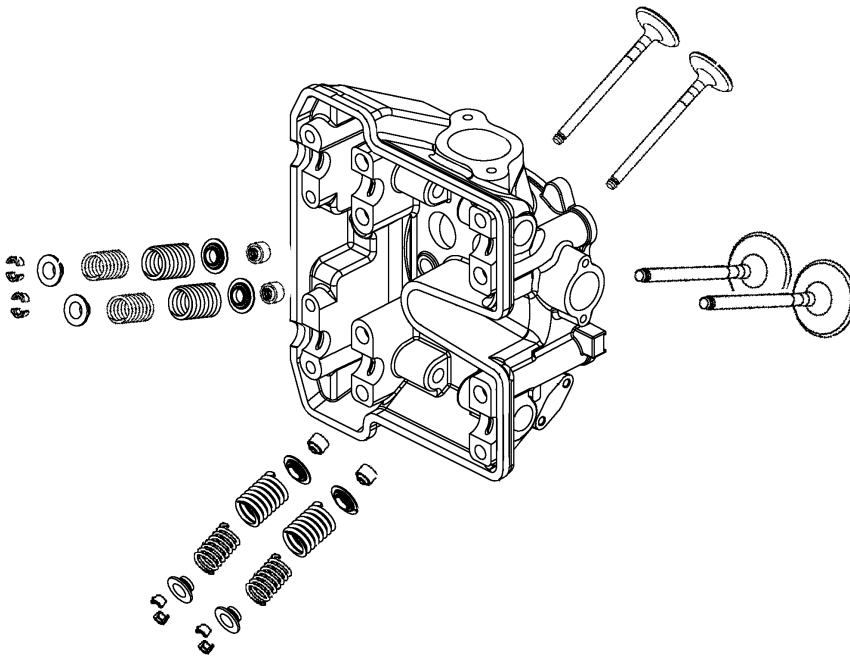

## 9. CYLINDER HEAD/VALVES XCITING 500/500 AFI/250/300 AFI

### VALVE /VALVE GUIDE INSPECTION

Inspect each valve for bending, burning, scratches or abnormal stem wear.  
If any defects are found, replace the valve with a new one.

Check valve movement in the guide.

Measure each valve stem O.D.

Measure each valve guide I.D.

Subtract each valve stem O.D. from the corresponding guide I.D. to obtain the stem-to-guide clearance.

#### Service limits:

**IN: 0.08 mm (0.0032 in)**

**EX: 0.1 mm (0.004 in)**

\* If the stem-to-guide clearance exceeds the service limits, replace the cylinder head is necessary.

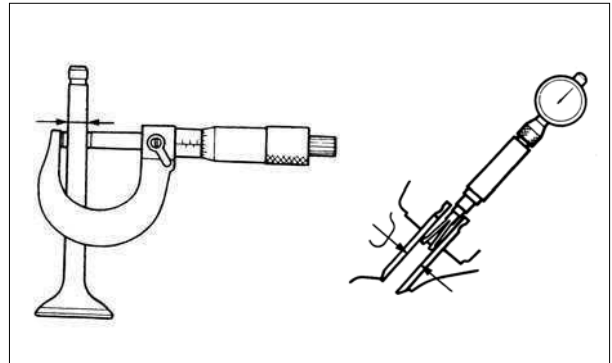

### CYLINDER HEAD INPECTION

Check the spark plug hole and valve areas for cracks.

Check the cylinder head for warpage with a straight edge and feeler gauge.

**Service Limit: 0.05 mm (0.002 in)**

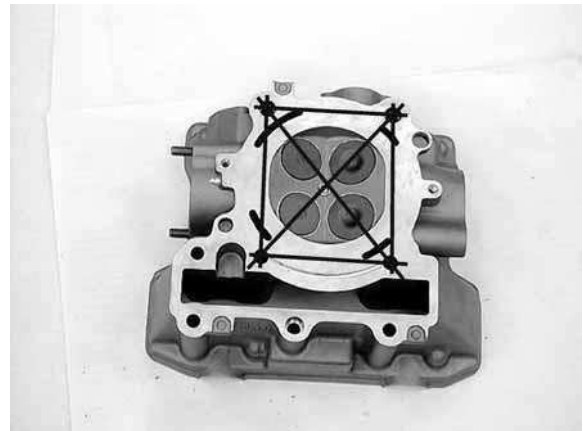

### VALVE SPRING INSPECTION

Measure the free length of the inner and outer valve springs.

#### Service Limit:

##### XCITING 500/500 AFI:

**Inner: 33.4 mm (1.336 in)**

**Outer: 38 mm (1.52 in)**

##### XCITING 250/300 AFI:

**Inner: 29.1 mm (1.164 in)**

**Outer: 39.2 mm (1.568 in)**

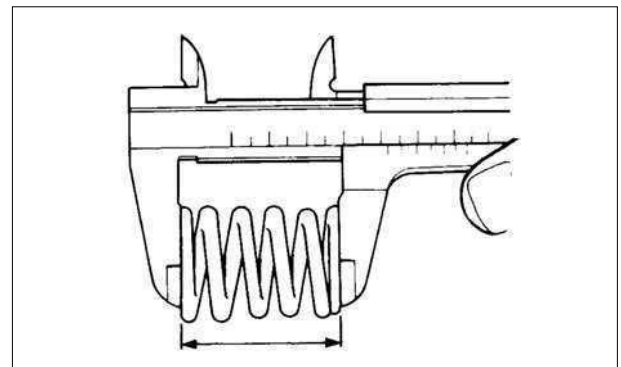



## 9. CYLINDER HEAD/VALVES

XCITING 500/500 AFI/250/300AFI

Measure compressed force (valve spring) and installed length.

Replace if out of specification.

**Standard (XCITING 500/500 AFI):**

**Inner: 3.5 kg (at 28.7 mm, 1.148 in)**

**Outer: 13 kg (at 31.43 mm, 1.2572 in)**

**Standard (XCITING 250/300 AFI):**

**Inner: 2.95 kg (at 26.6 mm, 1.064 in)**

**Outer: 10.45 kg (at 29.6 mm, 1.184 in)**

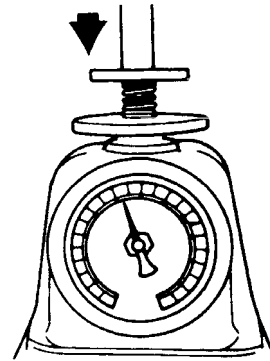

Measure the spring tilt.

Replace if out of specification.

**Standard (XCITING 500/500 AFI):**

**Inner: 1.2 mm (0.048)**

**Outer: 1.2 mm (0.048)**

**Standard (XCITING 250/300 AFI):**

**Inner: 0.81 mm (0.0324 in)**

**Outer: 1.07 mm (0.0428 in)**

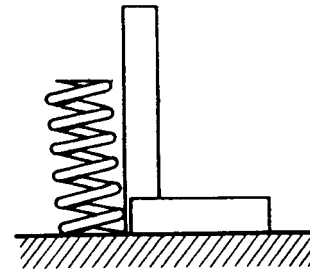

### ASSEMBLY

Install the valve spring seats and oil seal.

\*

Lubricate each valve with engine oil and insert the valves into the valve guides. Install the valve springs and retainers. Compress the valve springs using the valve spring compressor, then install the valve cotters.

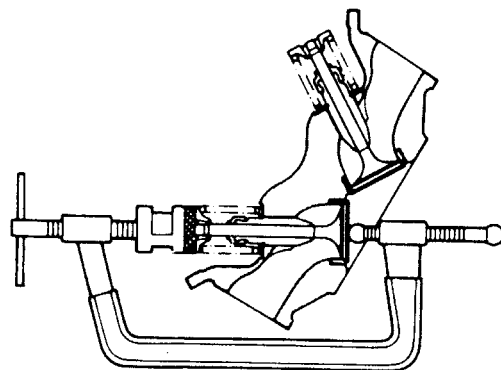

- \* • When assembling, a valve spring compressor must be used.  
• Install the cotters with the pointed ends facing down from the upper side of the cylinder head.

**Special tool:**

**Valve Spring Compressor A120E00040**

## 9. CYLINDER HEAD/VALVES XCITING 500/500 AFI/250/300 AFI

Tap the valve stems gently with a plastic hammer for 2~3 times to firmly seat the cotters.

\* Be careful not to damage the valves.

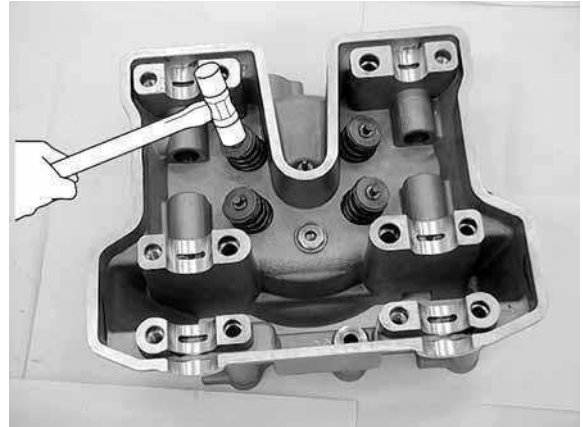

### INSTALLATION (XCITING 500/500 AFI)

Install the dowel pins and new cylinder head gasket as shown.

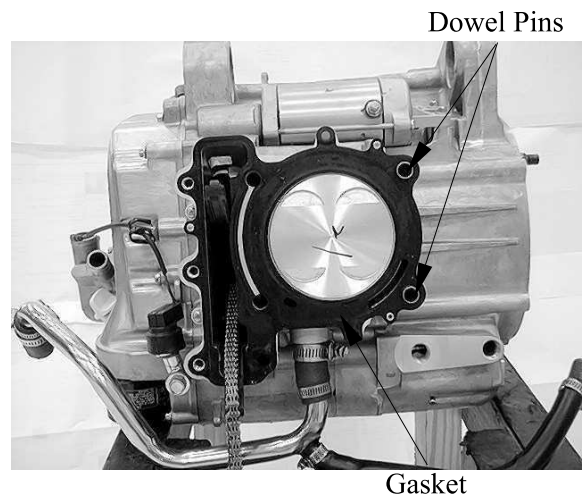

Install the cylinder head.

Apply engine oil to the cylinder head bolt (9) threads.

Install the two cylinder bolts and cylinder head bolt (9) but do not tighten them.

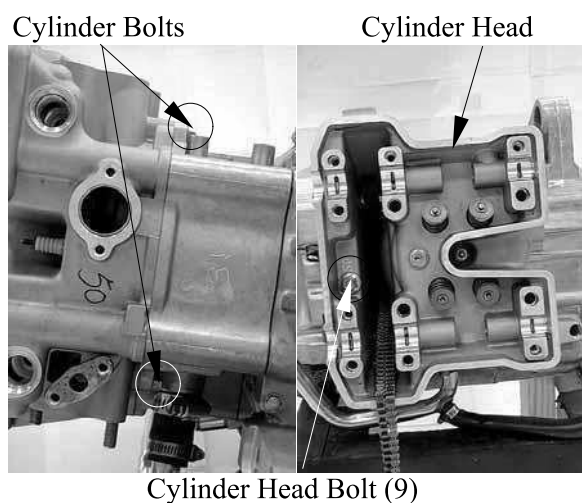

## 9. CYLINDER HEAD/VALVES

Install the water stop collar, gasket and water joint.

Install and tighten the two bolts to the specified torque.

**Torque: 12 N•m (1.2 kgf•m, 9 lbf•ft)**

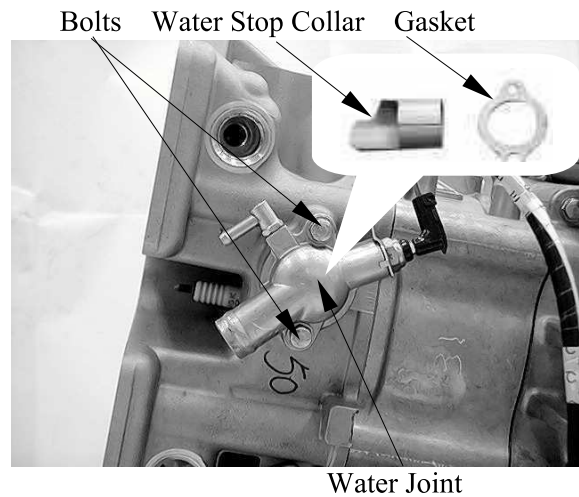

Install gasket and pair reed valve.

Install and tighten the four bolts securely.

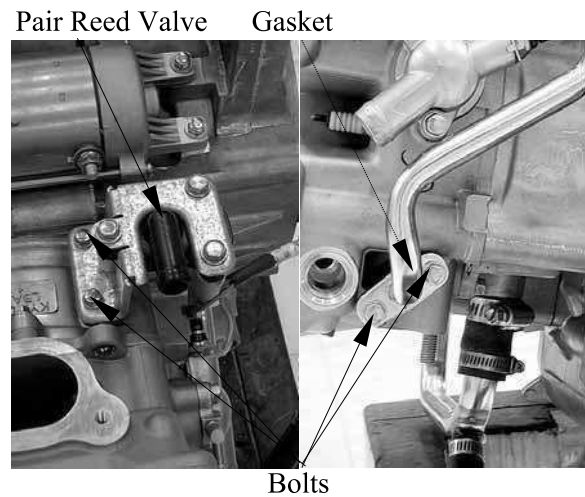

Install the new O-rings onto the insulator and intake pipe.

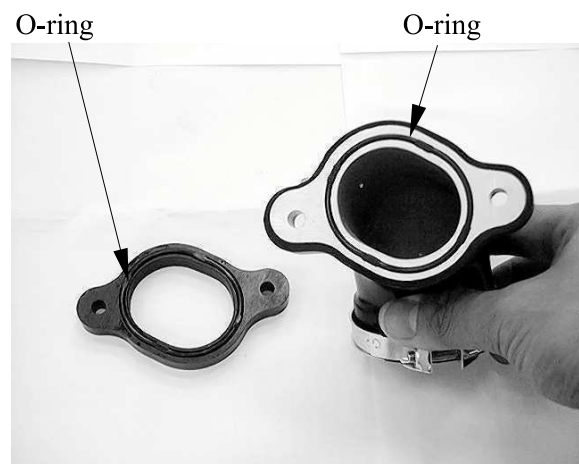

## 9. CYLINDER HEAD/VALVES XCITING 500/500 AFI/250/300 AFI

Install the insulator with the O-ring face the cylinder head.

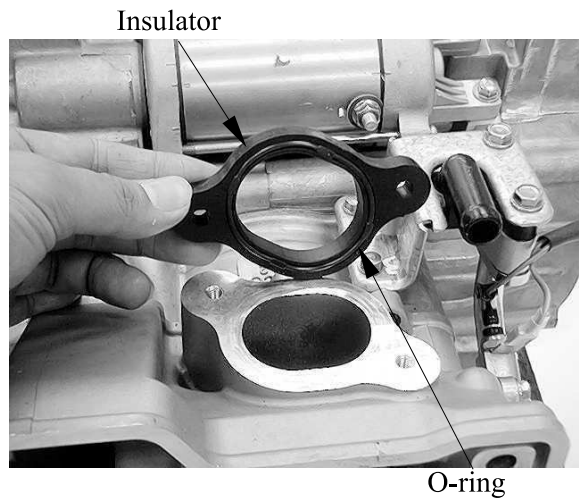

Install the intake pipe and tighten the two bolts securely.

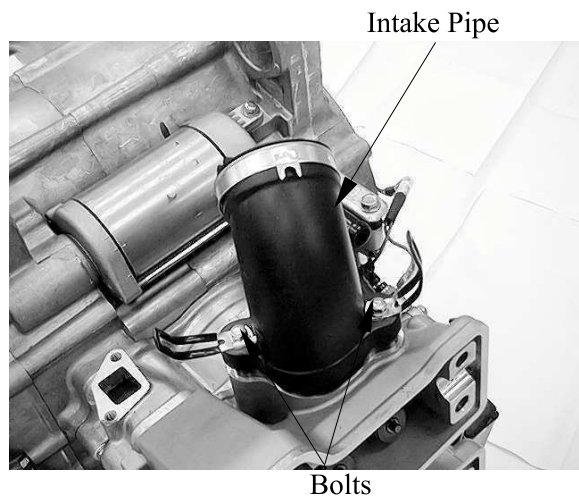

### ROCKER ARM INSTALLATION (XCITING 500/500 AFI)

Apply engine oil to the rocker arms and rocker arm shafts

Install the rocker arms, rocker arm shafts and washers.  
Tighten the rocker arm shaft to the specified torque.

**Torque: 45 N•m (4.5 kgf•m, 32 lbf•ft)**

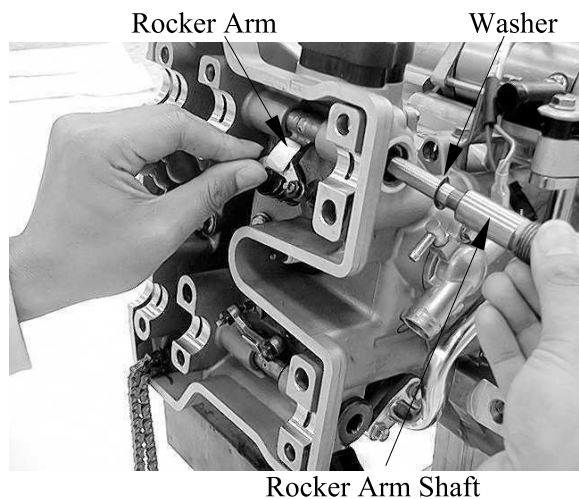

## 9. CYLINDER HEAD/VALVES

### CAMSHAFT INSTALLATION (XCITING 500/500 AFI)

Turn the crankshaft clockwise, align the “T” mark on the flywheel with the index mark on the right crankcase cover (page 3-12).

Apply molybdenum disulfide oil to the camshaft journals of the camshaft holder.



Apply molybdenum disulfide oil to the camshaft journals of the cylinder head.

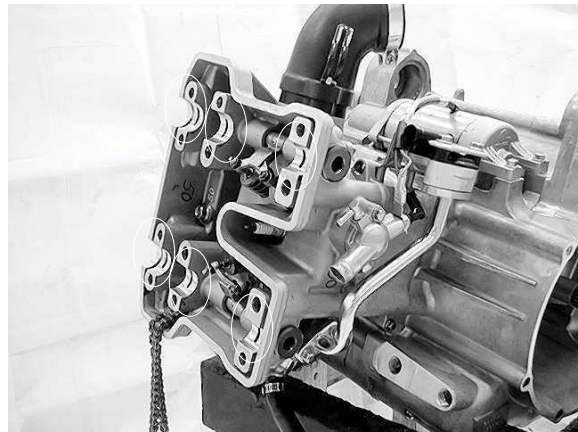

Install the cam chain over the cam sprockets and then install the intake and exhaust camshafts.

\*

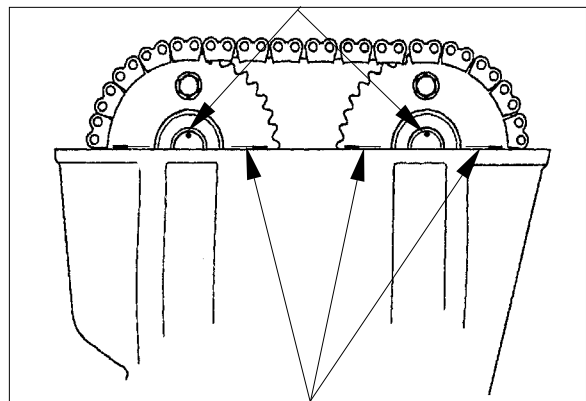

# 9. CYLINDER HEAD/VALVES XCITING 500/500 AFI/250/300 AFI

Install intake and exhaust camshaft holders to the correct locations.

- \* Install each camshaft holders to the correct locations.
  - “IN”: no stop pin.
  - “EX”: has a stop pin.

Apply engine oil to cylinder head bolt (No. 1 – 9) threads.

Install and tighten the holder bolts (No. 1 – 9) in a crisscross pattern in four steps to the specified torque as follow diagram.

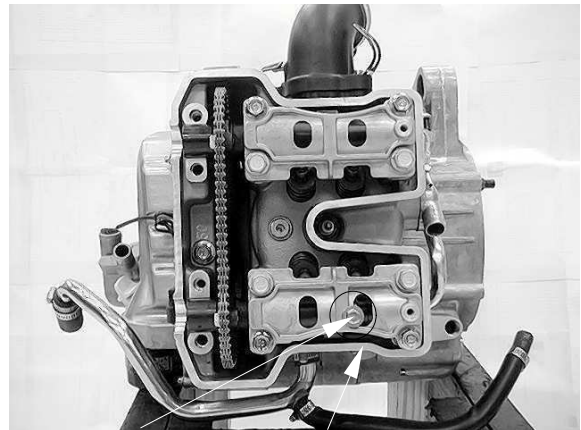

Stop Pin      Exhaust Camshaft Holder

Tighten the bolts to the specified torque in sequence									
N•m (kgf•m, lbf•ft)									
	(1)	(2)	(3)	(4)	(5)	(6)	(7)	(8)	(9)
<b>Step 1</b>	18 (1.8, 13)	←	←	←	12 (1.2, 9)	←	←	←	←
<b>Step 2</b>	48 (4.8, 35)	←	←	←	23 (2.3, 17)	←	←	←	←

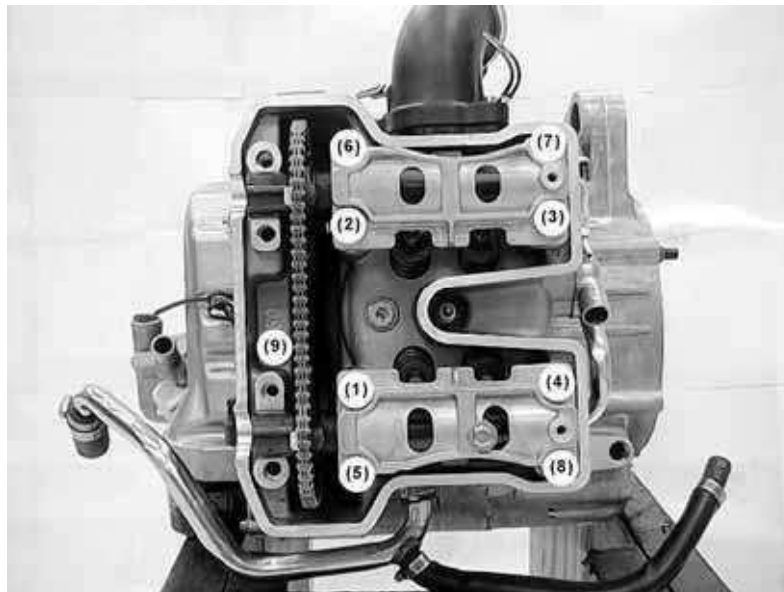



# 9. CYLINDER HEAD/VALVES

XCITING 500/500 AFI/250/300AFI

Install the common camshaft holder by arrow mark facing outside.

Install and tighten the holder bolts (No. 10 – 13) in a crisscross pattern in four steps to the specified torque as follow diagram.

\* Apply engine oil to cylinder head bolt (No. 10 – 13) threads.

Tighten the bolts to the specified torque in sequence								
N•m (kgf•m, lbf•ft)								
	(10)	(11)	(12)	(13)				
<b>Step 1</b>	12 (1.2, 9)	←	←	←				
<b>Step 2</b>	23 (2.3, 17)	←	←	←				

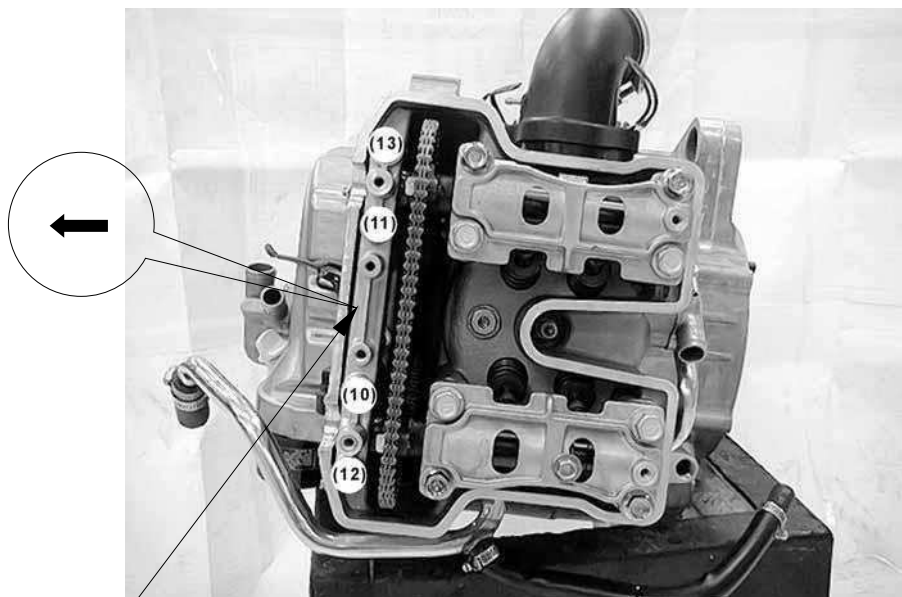

“Arrow” Mark

Tighten the two cylinder bolts to the specified torque.

**Torque: 10 N•m (1 kgf•m, 7 lbf•ft)**

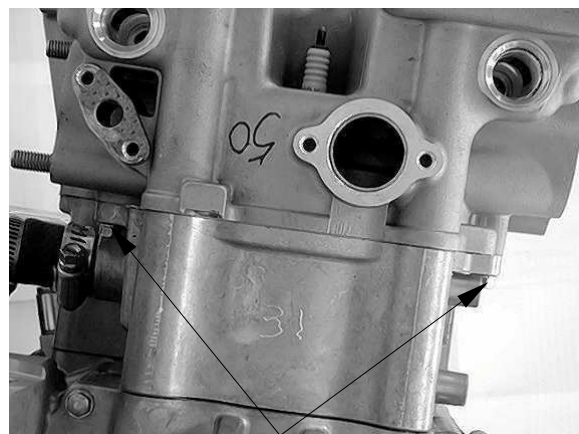

Cylinder Bolts

## 9. CYLINDER HEAD/VALVES

XCITING 500/500 AFI/250/300 AFI

Install the cam chain guide and tighten the two bolts securely.

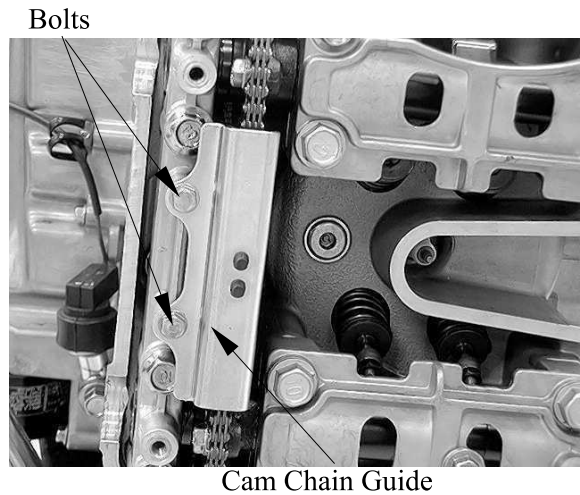

Release the timing chain tensioner one-way cam and push the tensioner rod all the way in.



Install the tensioner with a new gasket onto the cylinder.  
Install and tighten the tensioner bolts to specified torque.

**Torque: 12 N•m (1.2 kgf•m, 9 lbf•ft)**

Install the spring, washer and timing chain tensioner cap bolt to specified torque.

**Torque: 10 N•m (1 kgf•m, 9 lbf•ft)**

Adjust the valve clearance (page 3-12).

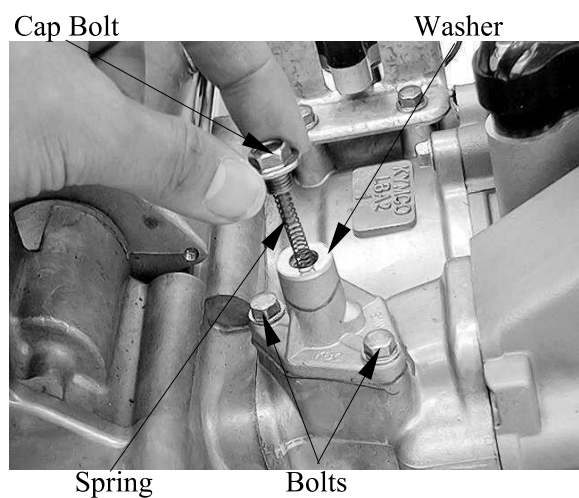



## 9. CYLINDER HEAD/VALVES

Install the cylinder head packing into the groove of the cylinder head cover.

Cylinder Head Cover Packing



Install the cylinder head cover onto the cylinder head and tighten the cylinder head cover bolts to the specified torque.

**Torque: 10 N•m (1 kgf•m, 7 lbf•ft)**

Bolts

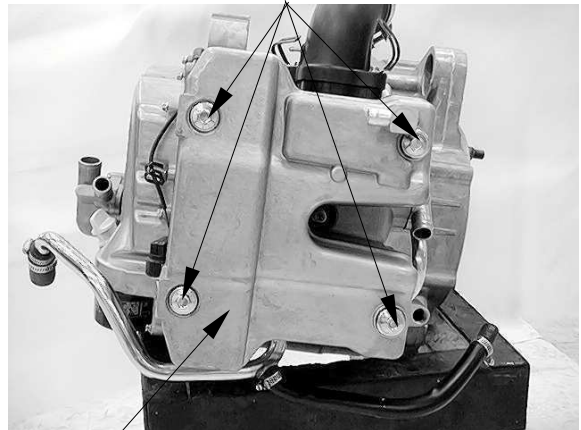

Cylinder Head Cover

## 9. CYLINDER HEAD/VALVES XCITING 500/500 AFI/250/300 AFI

### INSTALLATION (XCITING 250/250 AFI)

Install the cam chain guide.  
Install the dowel pins and a new cylinder head gasket.

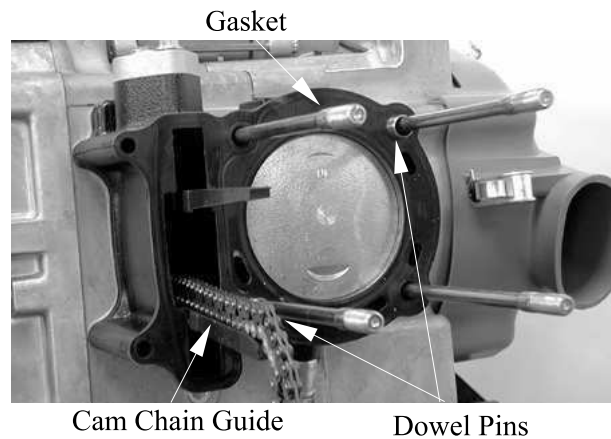

Install the cylinder head and take out the cam chain

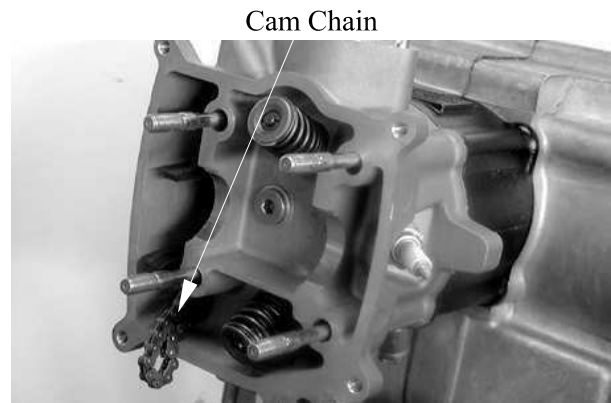

Assemble the camshaft holder.  
First install the intake and exhaust valve rocker arms; then install the rocker arm shafts.

- \* • Install the exhaust valve rocker arm shaft on the “EX” side of the camshaft holder and the exhaust rocker arm shaft is shorter.  
• Clean the intake valve rocker arm shaft off any grease before installation.  
• Align the cutout on the exhaust valve rocker arm shaft with the bolt of the camshaft holder.

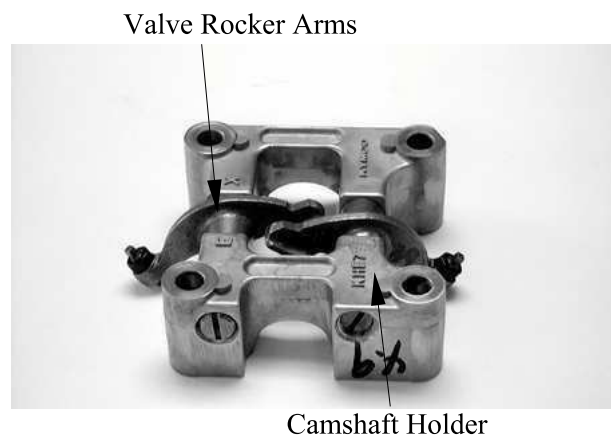

## 9. CYLINDER HEAD/VALVES

Turn the A.C. generator flywheel so that the “T” mark on the flywheel aligns with the index mark on the right crankcase cover. Keep the round hole on the camshaft gear facing up and align the punch marks on the camshaft gear with the cylinder head surface (Position the intake and exhaust cam lobes down.) and install the cam chain over the camshaft gear.

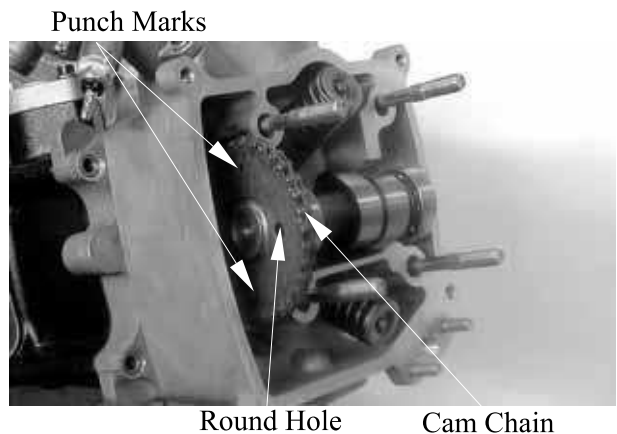

Install the dowel pins.

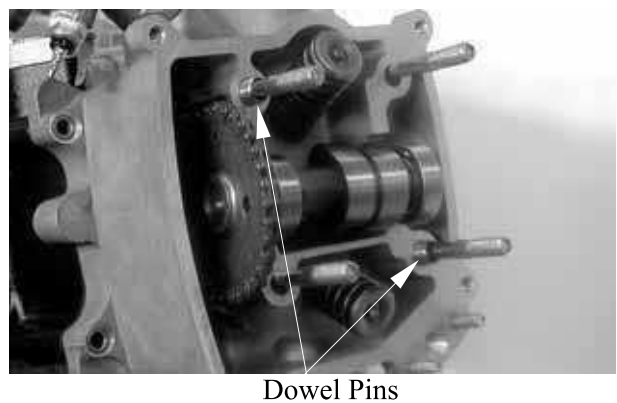

Install the camshaft holder, washers and nuts on the cylinder head. Tighten the four cylinder head cap nuts and two cylinder bolts to the specified torque.

**Torque:**

**Cylinder head cap nut:**

**25 N•m (2.5 kgf•m, 18 lbf•ft)**

**Apply engine oil to threads**

**Cylinder bolt: 10 N•m (1 kgf•m, 7 lbf•ft)**

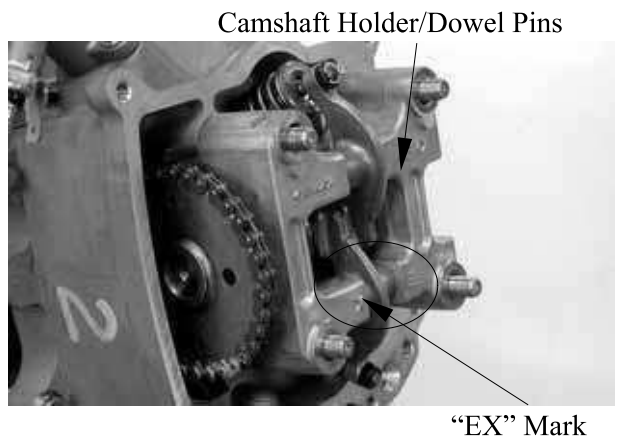

- \*
- Install the camshaft holder with the “EX” mark face exhaust valve side.
  - Apply engine oil to the threads of the cylinder head cap nuts.
  - Diagonally tighten the cylinder head cap nuts in 2~3 times.
  - First tighten the cylinder head cap nuts and then tighten the cylinder bolts to avoid cracks.

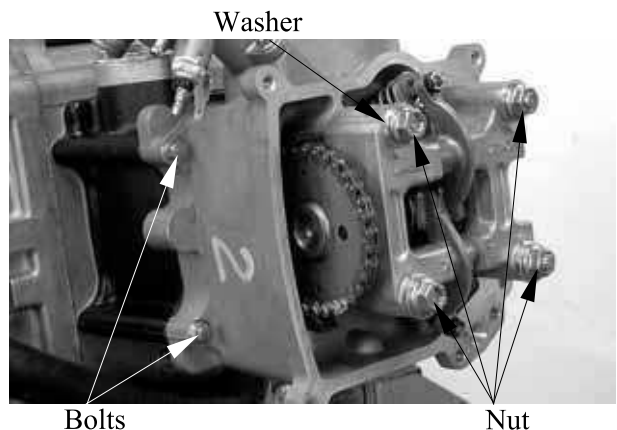

## 9. CYLINDER HEAD/VALVES

XCITING 500/500 AFI/250/300 AFI

Turn the cam chain tension screw counterclockwise to release it.

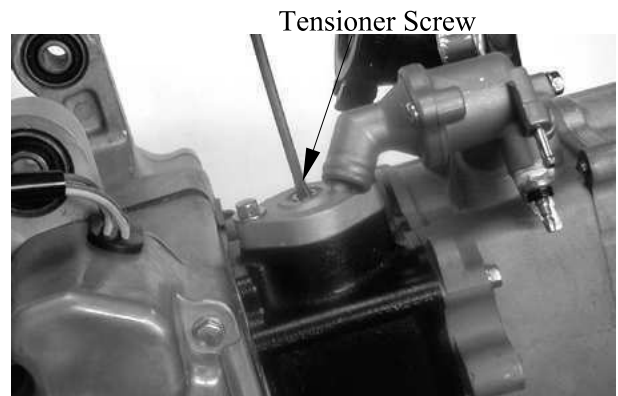

Apply engine oil to a new O-ring and install it.  
Tighten the cam chain tension cap screw.

\* Be sure to install the gasket into the groove properly.

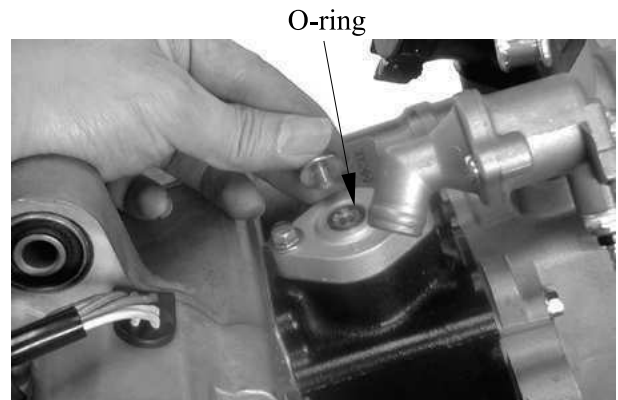

Adjust the valve clearance. (page 3-13).

Install a new cylinder head cover O-ring and install the cylinder head cover.

\* Be sure to install the O-ring into the groove properly.

Install and tighten the cylinder head cover bolts.

**Torque: 10 N•m (1 kgf•m, 7 lbf•ft)**

